

PLEASE READ THIS MANUAL THOROUGHLY
BEFORE USING THE INTERCOM
and consult with your A & P Mechanic or Certified
Repair Station prior to installation.



SYSTEM OVERVIEW

The Flightcom Model 403mc intercom is a monaural unit compatible with most aviation headsets. Installation of up to four stations is possible using optional jacks. The unit provides two station radio transmit capability.

Fig. 1 Typical Connection Configuration

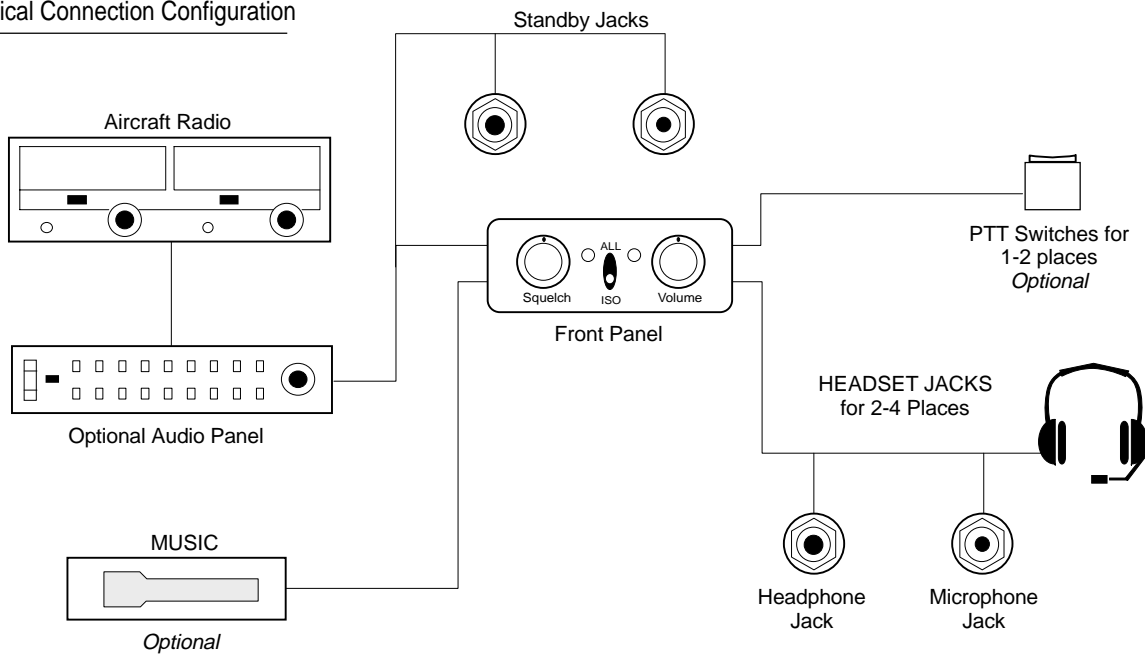

OPERATING PROCEDURES

Plug headsets into the proper intercom jacks. When using stereo headsets, put the stereo/mono switch in the mono mode. Turn on the aircraft master switch and avionics master, if so equipped.

Initially set the intercom volume control to the 11 o'clock position and the squelch control to the 3 o'clock position. Turn up each headset volume all the way and position your boom mic 1/8" from your lips and at the corner of your mouth for best results. Noise canceling mics will not operate correctly if they are more than 1/8" from your mouth. While speaking loudly, adjust the intercom volume control to a comfortable listening level.

Squelch Control: The squelch control should be set as far clockwise as possible while still blocking the background noise. When adjusting the squelch, be sure no one is talking. Re-adjust this setting in flight to compensate for different noise levels.

Note: If the squelch is set too high (counter-clockwise) your voice will be cut out unless you talk very loudly. If the squelch is set too low (clockwise) the background noise will be heard occasionally.

Fig. 2 Correct Placement of Boom and Mic

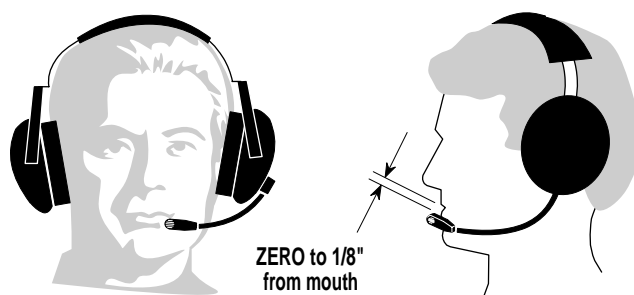

RADIO USE

Normal radio use is unaffected by proper installation of the intercom, and passengers will now be able to hear each other, the aircraft radio, and sidetone, (if radio generated). To transmit on the radio, push the yoke PTT switch associated with your headset, (pilot or copilot). There is no need for the passengers to stop talking while the pilot is transmitting. Only the person whose push-to-talk switch is depressed will be heard over the radio. An instructor can talk to a student pilot over the intercom, while the student is transmitting over the radio without the instructor's voice also being broadcast. Music will never be transmitted. If your push-to-talk switch fails, you can use an existing handheld mic to talk on the radio while listening over the intercom.

Pilot Isolate Switch: For normal intercom and transmit operations place the PILOT ISOLATE switch in the ALL position. Selecting the ISO setting will isolate the pilot from the intercom conversation (and music) and connect the pilot directly to the aircraft radio. Placing the PILOT ISOLATE switch in the ISOLATE position will prevent the passengers from hearing the aircraft radio receptions as well as the pilot's transmissions to ATC. Passengers can continue to use the intercom, including a music source.

Fig. 3 Pilot Isolate Switch Location

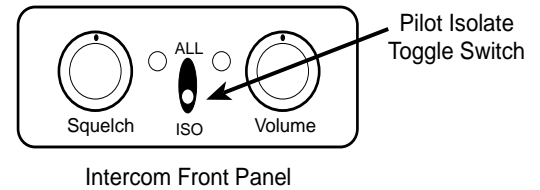

Fig. 4 Pilot Isolate Switch

	Pilot Hears:	All Others Hear:
ALL	Intercom Radio, Music	Intercom Radio, Music
ISO	Radio Only	No pilot, but Intercom, Music

Intercom Failsafe Feature: The integral failsafe relays in the intercom will connect the pilot's headset directly to the aircraft radio in the event of a power supply interruption to the intercom.

Music Muting: When music or other input is being played via the auxiliary input, an instant muting feature will prevent interference with critical voice communications. (See Figure 6a below)

Note: This feature must be wired into the wiring harness when the intercom is installed into the aircraft. (See Figure 12 CONNECTION SCHEMATIC). (Connect pin #24 on the DB25 connector to pin #25 to permanently install this feature. A switch installed between these pins would give the option of using or not using this muting feature.) (See Figure 6a below)

Intercom Muting: This instant muting feature will allow the incoming radio communications to have priority over the intercom feature and will mute the intercom audio.

Note: This feature must be wired into the wiring harness when the intercom is installed into the aircraft. (See Figure 12 CONNECTION SCHEMATIC) Connect pin #23 on the DB25 connector to pin #25 to permanently install this feature. A switch installed between these pins would give the option of using or not using this muting feature.

Fig. 5 Intercom Muting

Pin 25 (common) connected to: (indicated with "x")

Pin 23	Pin 24	
		No Muting
x		Radio Mutes Intercom only
	x	Radio Mutes Music Only
x	x	Radio Mutes Intercom Audio and Music (CONNECTOR PRE-WIRED FOR COMPLETE RADIO PRIORITY)

Fig. 6a Selectable Auto Mute

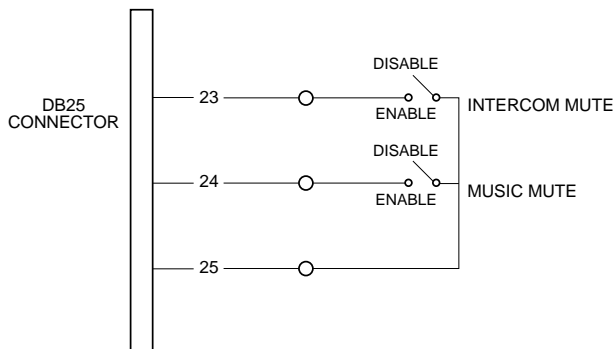
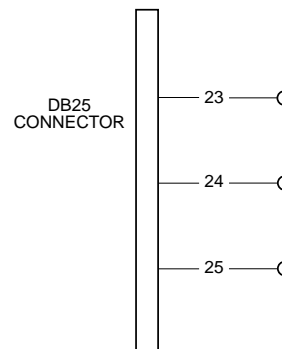

Fig. 6b Factory Shipped Muting Configuration



Complete Radio Priority: Connecting pins #23, #24 and #25 on the DB25 connector will give the radio complete priority and the radio will override all other audio in the model 403mc. **Note:** The DB25 connector shipped with the model 403mc intercom is pre-wired for complete radio priority. (See Figure 6b)

INTERCOM INSTALLATION

For In-panel or Under-panel Mount: The intercom box measures 2.375"W x 1"H x 2.625"D. Depending on the type of housing used on your selected DB25 connector, allow at least an additional 3/4" in depth for mounting. If you're using the Flightcom supplied DB25 connector, allow an additional 2" in depth. The intercom can be placed either vertically or horizontally in the instrument panel, under the panel, or in any other suitable location in the aircraft.

For In-panel Mounting: Leave the two potentiometer nuts in place on the intercom. Mark the panel by placing the front panel plate in the location of your choice, either vertically or horizontally, and trace the hole location for drilling.

For panels less than .1" thick (Drill Template #1 — See figure 10) use a 9/32" drill for the controls. For panels between .1" and .2" thick (Drill Template #2 — See figure 10) use a 1/2" drill or punch so the nuts can be cleared.

Insert the intercom through the panel and the faceplate of your choice and install the two 4-40 x 1/2" mounting screws. **DO NOT USE ANY REPLACEMENT SCREWS LONGER THAN 1/2 INCH!** Install knobs so that the mark points to the 7 o'clock position when fully counter-clockwise.

Fig. 7 Control Panel Installation

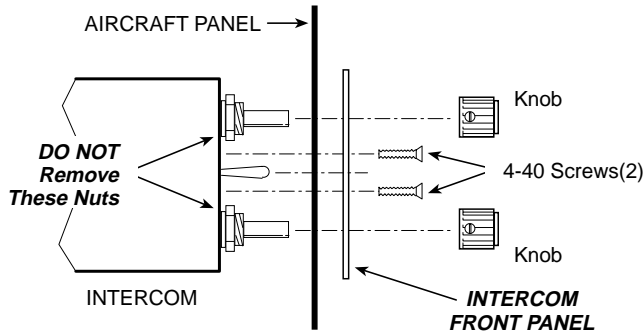

Note: Use the two flathead screws when mounting the horizontal faceplate. Use the two panhead screws when mounting the vertical faceplate.

Headphone and Microphone Jacks: Choose a location for each pair of jacks (one microphone, one headphone) for each station, up to a total of 4 stations. Carefully mark each location. Drill a 3/8" hole for each headphone jack and a 1/2" hole for each microphone jack/shoulder washer. Connect the jacks with the proper wire and according to the wiring diagram on page 7.

The intercom microphone jacks must be insulated from the airframe, but the headphone jacks may either be grounded to the airframe or insulated with a separate ground wire running back to the intercom.

Note: Do not use the same ground wire for the headphone and microphone jacks.

Fig. 8 Jack Mounting Diagram

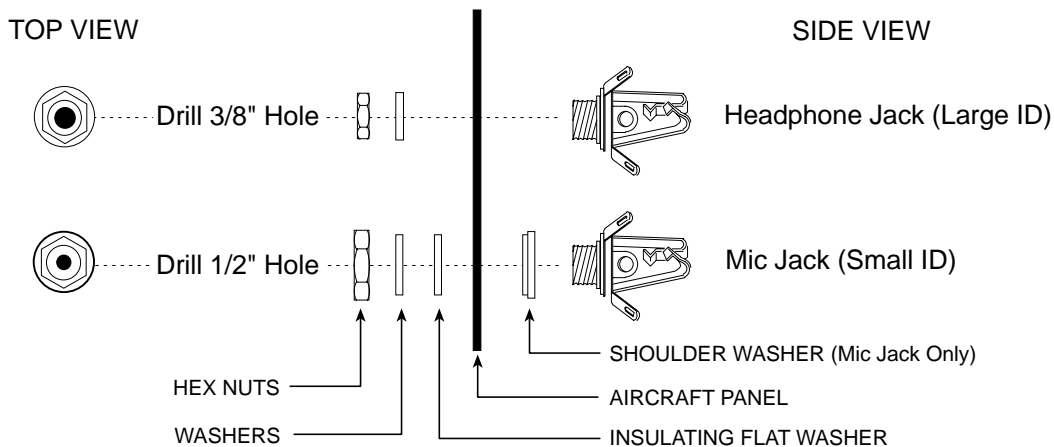

(Headphone and microphone jack info continued next page.)

IMPORTANT: The existing aircraft headphone and microphone jacks must be left in place and may be used as a convenient tie-in point to connect wires 8, 17, and 21 to the radio. They will also serve as a standby radio connection in case the intercom is ever removed for servicing. Wires 2, 7, and 9 must be connected to different (new) jacks.

Note: If your aircraft does not have a built-in Push-to-Talk switch, you will need to acquire a portable switch and plug it into another microphone jack, installed in parallel with the pilot's microphone jack. You would not use the in-line jack on the PTT switch in this situation. Optionally, you could use the same mic jack if the PTT switch were modified (see Fig. 9) to defeat the mic audio interrupt feature inherent in most portable PTT switch models.

The copilot can transmit over the radio if pin 6 is connected to an existing copilot PTT switch and pins 16 & 17 are connected together.

Note: *The DB25 connector shipped with the model 403mc intercom is pre-wired this way.*

AUXILIARY INPUT AND OUTPUT:

(See Wiring Diagram) If a music source is not installed permanently in the aircraft (Auxiliary Input), a 3.5mm mini jack can be installed in a convenient location to provide an interface for a portable recorder or CD player. The system output will be monophonic. Pin number 18 on the wiring diagram is for auxiliary input, allowing you to listen to a tape player or other source. To record from the intercom system (Auxiliary Output), install a second 3.5mm jack and connect it via one (1) 47k resistor to the pilot's headphone output, pin 9. DO NOT attempt to combine both input and output functions on a single 3.5mm jack.

INTERCOM WIRING INSTRUCTIONS:

Use 20 or 22 gauge teflon-coated wire, (not provided). We suggest a 25 watt soldering iron. Route all wires away from aircraft controls. Make sure that wires do not chafe on or come in contact with the control cables, push rods, trim actuators, chains, flap followers, etc. Avoid bundling wires with RF coaxial cables, inverter, or synchro wiring. Use shielded wire on audio mic and headphone lines.

Make good solder connections and insulate connections with heat shrink tubing. Refer to the WIRE CONNECTION GUIDE and the CONNECTION SCHEMATIC for connector pin numbers and connection information. The numbers on the diagram are on the solder terminal side of the connectors. Connect the intercom power lead (pin 20) to a circuit breaker on the Avionics Power Bus. Do not connect to Flight Instrument Power. Avoid circuits with motors, strobes, or other "noisy" devices. If you are not sure where to obtain power, consult with an avionics shop before proceeding.

HINTS AND TIPS:

If you have difficulty transmitting on the radio: Make sure the pilot's and copilot's microphones are not interchanged, and that the PTT lines go to the correct switches. If this problem appears initially just after installation, check wires 2, 7, 8, and 17 for proper wiring. If you experience a distorted sidetone while transmitting, it relates to improper shielding of the aircraft antenna cable. Usually, the tower receives you loud and clear in spite of what it sounds like in the cockpit.

If you do not hear a sidetone while transmitting on the radio: If a sidetone is not heard, there are several possibilities: One, the radio sidetone level may be adjusted too low or turned off. Two, perhaps the radio wasn't designed with a sidetone output, or it was not connected during radio installation. Turn up the radio sidetone output if possible.

If the unit is completely dead: Make sure that the aircraft master switch is turned on. Check the power supply lead (pin 20) to make sure there is voltage available between it and pin 1 (ground). Make sure the fuse or circuit breaker is intact. For an initial problem after installation, verify that the wire number is correct. Check to see if the headphones are plugged in all the way. Verify that headset volume controls are turned up. Are the headphone plugs corroded? Use steel wool or crocus paper to shine up the headset plugs. Be sure that the squelch is set properly, as the intercom is quiet when muted.

If a high pitched whine varies with engine RPM: This is from an alternator or generator noise on the power bus of the aircraft. Check the filter at the generator/alternator. Insulate all microphone jacks from the aircraft frame and run a separate ground wire to the intercom from each jack. Be sure the ground lead from the intercom (pin 1) is connected to an avionics ground. In very bad cases, a commercial alternator noise filter can help. Connect it in series with the intercom power lead. In severe cases there may be a blown diode in the alternator or a bad aircraft battery.

If the unit isn't loud enough or you lose parts of your sentences: Place the microphone as close to your lips as possible. **IMPORTANT!** Make sure the squelch is not adjusted too high. While no one is talking, slowly rotate the squelch control just until the background noise disappears. Do not turn the knob any further than necessary. Good headsets make a big difference here. You may find that one brand puts out a higher signal than another. Attempt to equalize the sensitivity of all your headsets by adjusting the mic pre-amps (contained in the mic itself or in the ear cup).

If you are unable to squelch out all the background noise: Note that David Clark H10-30 headsets require that the mic preamp be turned down all the way. This is accomplished by rotating the small nylon screw at the front of the mic fully counter-clockwise. Single earsets or other tubular mic type headsets may not have the noise-canceling ability necessary for proper squelch operation. A full earmuff with a high-quality noise-canceling electret or amplified microphone is the best way to go, although all aviation headsets will work to some degree.

If the background noise level is too high while speaking: The source is with the noise-canceling ability of the mic itself. Just one poor mic will make the entire system noisy. Experiment with other headsets, using other planes and radios if necessary. Replace defective headsets with good quality units, preferably with electret mics. Another approach is to turn down the volume control until the noise is at an acceptable level and speak with more volume, the mic nearly touching your lips. This increases the signal to noise ratio by increasing the strength of your voice against the apparent strength of the noise.

If it still doesn't work: Call or write with a detailed description of the problem. Most of the time an explanation will solve the situation. Don't return the unit without contacting us first, since 98% of the time we are able to diagnose the problem via telephone, back to the installation, the method of operation, the radio itself, or the headsets.

PROCEDURE FOR WARRANTY CLAIM

Please send in your warranty card promptly. When returning a unit for repair, enclose a copy of your original, dated bill of sale or the installation certificate as proof of purchase. Defective units must be shipped to us with the freight prepaid.

Fig. 9 PTT (Push-to-Talk) Switch Modification

Mic audio needs to go straight through and not be switched. Make modification inside the in-line jack or switch housing. Use a continuity tester to locate the wire from the ring connector of the mic plug.

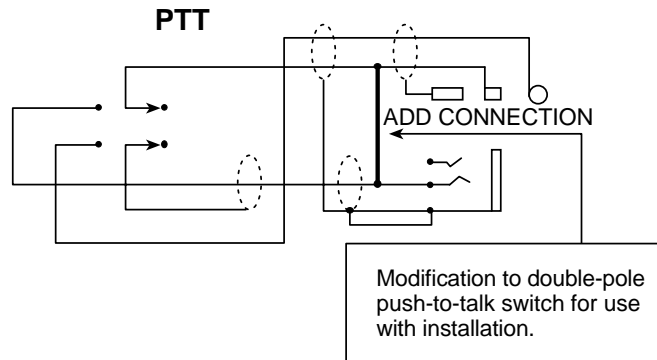
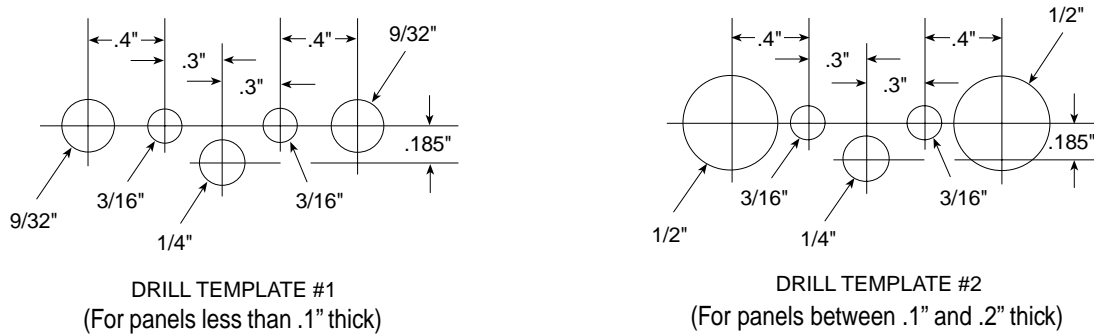
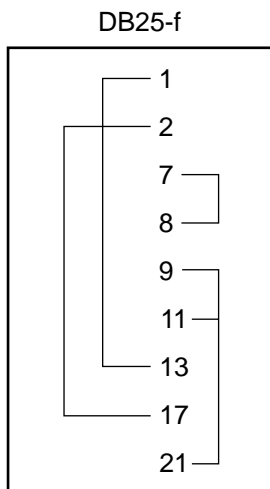

Fig. 10 Drill Templates



In the event that you need to remove your intercom for service, we suggest the following wiring as a by-pass plug, so that radio audio may still be heard, even when the intercom is removed.

Fig. 11 By-Pass Plug Wiring Diagram



SPECIFICATIONS

Size: 2.375"W x 1"H x 2.625"D
 Weight: 3.6 ounces
 Output 375 milliwatts into each 150 ohm
 headset. Sound level remains constant
 regardless of the number or type of
 headsets connected.
 Power Requirements: 0.16 amps, 12-28VDC
 Warranty 1 Year Parts & Labor

PARTS LIST

1 25-pin D-sub connector housing
 1 Faceplate
 2 Knobs
 4 4-40 Screws (black)
 1 25-pin D-sub connector (male)
 1 403mc Intercom
 1 Manual
 4 Headphone Jacks*
 4 Mic Jacks*
 8 Nuts*
 8 Washers*
 4 Black Washers*
 4 White Nylon or Fiber Washers*

**When purchased with all possible optional jacks*

WIRE CONNECTION GUIDE

The following connector pin numbers correspond to the numbers located on the D-sub connector provided with your intercom:

CONNECTOR PIN	INTERCOM FUNCTION	AIRCRAFT CONNECTION
Pin #1	Ground	Avionics ground point
Pin #2	Mic Audio	Pilot mic
Pin #3	Mic Audio	Copilot mic
Pin #4	Mic Audio	Passenger mic
Pin #6	Copilot	Copilot PTT Switch
Pin #7	Pilot key	Pilot PTT Switch
Pin #8	Transmit key	Comm radio keyline
Pin #9	ICS Audio	Pilot headphone
Pin #11	ICS Audio	Passenger headphones
Pin #13	Mic return	All mic jacks
Pin #14	Mic Audio	Passenger mic
Pin #16	Copilot Transmit Audio	Comm radio
Pin #17	Pilot Transmit Audio	Comm radio
Pin #18	Aux input	Music system
Pin #20	Power in	12-28 V, 1 amp breaker
Pin #21	Receive Audio	NavCom/Audio Panel
Pin #23	Intercom Mute	None
Pin #24	Aux Mute	None
Pin #25	Mute Activate	None

Fig. 12 Connection Schematic

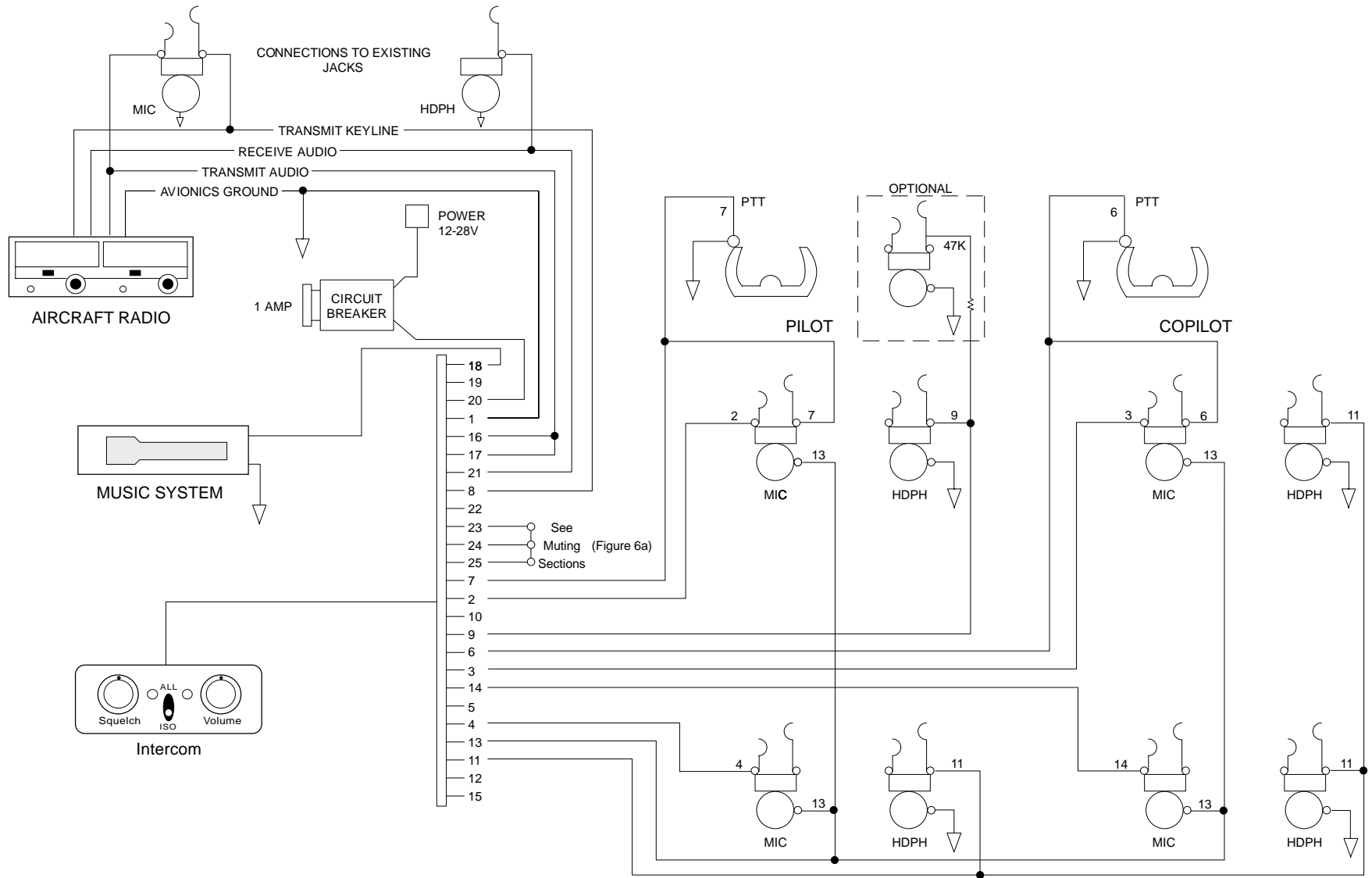

NOTE: Aux. Input is Pin No. 18

Fig. 13 Intercom Functional Block Diagram

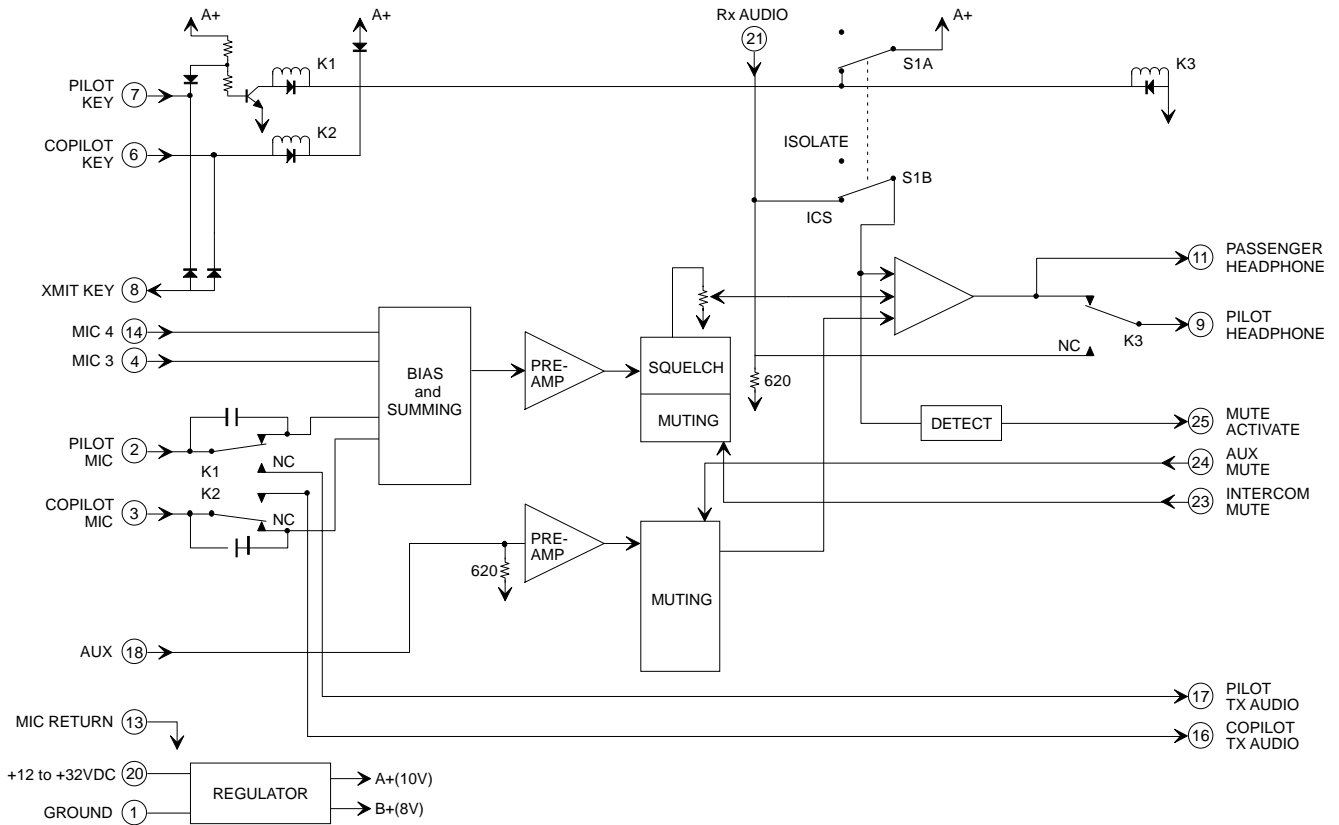

Flightcom Corporation
 7340 SW Durham Rd., Portland, Oregon 97224
 Phone: (503) 684-8229 Fax: (503) 620-2943

One-Year Limited Warranty to Original Purchaser

Flightcom Corporation warrants to the original purchaser of this product that it will be free from defects in materials and workmanship under normal and proper use for the period of one year from date of purchase. Flightcom Corporation will repair or replace, at its option, any parts showing factory defects during this warranty period, subject to the following provisions. This warranty applies only to a new product which has been sold through authorized channels of distribution. All work under warranty must be performed by Flightcom Corporation. All returned products must be shipped to our address, freight prepaid, accompanied by a dated proof of purchase. **SAVE YOUR SALES SLIP!** The purchaser voids this warranty if he, she or others attempt to repair, service or alter the product in any way. This warranty does not apply in the event of accident, abuse, improper installation, unauthorized repair, tampering, modification, fire, flood, collision or other damage from external sources, including damage which is caused by user replaceable parts (leaking batteries, etc.). This warranty does not extend to any other equipment or aircraft to which this product may be attached or connected. The foregoing is your sole remedy for failure in service or defect. Flightcom Corporation shall not be liable under this or any implied warranty for incidental or consequential damages, nor for any installation or removal costs or other service fees. This warranty is in lieu of all other warranties, express or implied, including the warranty of merchantability or fitness for use, which are hereby excluded. To the extent that this exclusion is not legally enforceable, the duration of such implied warranties shall be limited to two years from date of purchase. No suit for breach of express or implied warranty may be brought after two years from date of purchase.

Copyright © May 1996 FLIGHTCOM CORPORATION. Printed in USA. ALL RIGHTS RESERVED.
 Specifications subject to change without notice.